

Service Guide

**E•DRIVE Design Inc.
Heavy Duty
Linear Actuators**

Eliminator HD™



Quality Since 1980

Contents

Important Information for Users	2
Installation Considerations	3
Air Purge and Vent	4
Lubrication	4
Maintenance	5
Gearbelt Installation/Tensioning	5
Switch Wiring	6
Warranty	7

Engineering Assistance

E•DRIVE Design Inc.
120 Vanderbilt Avenue
West Hartford, CT 06110

Repair Service

Please ship repairs to:

E•DRIVE Design Inc.
120 Vanderbilt Avenue
West Hartford, CT 06110

Phone 860.953.0588 • Fax 860.953.0496
www.edriveactuators.com

E•DRIVE Linear Actuators

Important Information for Users Installation and Operation

E•DRIVE Linear Actuators must be installed and operated in such a way that all applicable safety requirements are met. As an installer, it is your responsibility to identify and comply with all relevant safety standards. Severe personal injury as well as equipment damage may result from any failure to heed this warning. Read and understand this entire service guide before installation and operation of this equipment.

The installation and maintenance of this actuator should only be performed by personnel who have been appropriately trained. Such persons should be familiar with the potential hazards associated with electrical and mechanical equipment. The individual or group having overall responsibility for this equipment must ensure that operators are adequately trained.

Under no circumstances will E•DRIVE be liable for any incidental, consequential, or special damages resulting from use or misuse of this equipment or this service guide.

Safety Warning

Motion equipment is capable of rapid movement and very high forces. Unexpected motion may occur at any time. KEEP CLEAR of any machinery until the on site supervisor has determined that all sources of electrical or mechanical potential energy have been disabled or otherwise “locked out”. Avoid contact or physical proximity to the actuator, while it is in operation.

This product is sold, as a component, to be installed in a complete system using good engineering practice.

E•DRIVE continually strives to improve all of its products, therefore we reserve the right to modify equipment and service guides without prior notice.

E•DRIVE Actuators

Product Description

E•DRIVE Linear Actuators are based on a high efficiency anti-friction screw, supported in bearings, and rotated by a motor. The nut is attached to the piston rod. By constraining the piston from rotating, the rotary movement of

the motor is converted into linear motion of the piston rod. The motor may be directly coupled or include a gearbelt drive or a third party gear reducer.

Mechanical and performance specifications can be found on our web site, www.edrivedesign.com, or by calling E•DRIVE at 860.953.0588. All inquiries should include the actuator serial number, this is a number with a "P" prefix and is inscribed on a metal tag directly on the front cap.

Safety Considerations

In any situation where safe guards and control systems do not prevent accidental contact between personnel and the actuator, the machine builder/installer must provide suitable warnings.

Installation Considerations

In mounting any actuator, the following issues need to be considered:

- Avoid distortion of the actuator body
- Proper alignment of the actuator relative to the load travel
- Prevent side loading of the piston rod
- Linear acceleration and deceleration should not exceed 386 in/sec²
- Load, velocity, and motor input torque should not exceed catalog specifications

As with any ball bearing device, special care must be taken to avoid impact. Any impact will jeopardize actuator life. Install over-travel limit switches and connect to control circuitry, before energizing the motor, to reduce the possibility of damage through accidental extension or retraction beyond the mechanical limits of the actuator.

Motor Pulley should be inline with the ball screw pulley within 1/32 inch. Fasten pulley to motor shaft with supplied set screw or taper lock bushing.

Gearbelt should be properly tensioned. Gearbelt drives should not be extremely tight such as other belt drives (V-belt, Poly-V, Flat belt, etc.). If belt tension is too great, it imposes excessive and unnecessary loading on bearings. When the belt is too loose (particularly on high torque applications), belt may jump teeth. See page 6 for Installation/Tensioning.

E•DRIVE Linear Actuators

Coupling (inline only) Fasten one end of the coupling to the output shaft of the motor or gear reducer using the clamp. Verify and correctly position the coupling to fully engage the “spider”; also, the end of the shaft/coupling should not apply axial pressure to the ball screw shaft.

End Effectors Caution should be exercised when attaching any device to the end of the piston rod. Use the wrench flats on the piston end to prevent rotation while attaching the end effector. Any substantial torque applied to the piston rod may damage the internal anti-rotation system.

Ball Screw Pulley In the event this pulley is removed or replaced - DO NOT use the fully retracted or fully extended rod position to counter-act the applied wrench torque.

Air Purge and Vent

This actuator is a sealed chamber. As the piston is extended, the internal volume increases, creating a partial vacuum. Similarly, when the piston retracts, a positive pressure develops. When the linear motions are rapid, there may be a tendency during extension to draw airborne contaminants through the end seal; and similarly during retraction, to expel air through the seal. These conditions may compromise the seal integrity and subsequently lead to contamination of the ball screw system. We encourage the application of 2-3 psi of clean air to the actuator chamber to compensate for these air flows. If this air purge is not used, we suggest use of a filtered vent or plumbing pipe/hose to a source of clean air.

Lubrication

The standard lubrication is Mobiltemp SHC-32. As an option, the actuator can be supplied with a food grade grease, Mobil FM101.

1. Units have been pre-lubricated at assembly. Re-greasing is recommended every 500-1000 hours of actuator movement under load.
2. Caution - DO NOT mix different types of lubricant.
3. To re-grease, move the piston to its fully retracted position. Clean, then remove either switch mounting plate. Using a grease gun, apply grease sparingly. Be careful not to allow any debris into the cylinder chamber. Replace the switch mounting plate.

NOTE: Eliminator HD products use either standard or Flush type grease fittings.

Maintenance

1. Ball bearings are greased for life and require no maintenance.
2. Piston seals require periodic (6 month approx.) inspection.
3. Gear belts require periodic (6 month approx.) inspection for possible wear and proper tension.

The successful operation and longevity of this actuator is based on superior components, precise manufacturing, and extreme cleanliness. Unless your maintenance personnel are thoroughly familiar with this type of construction, any attempt to perform “field” repairs may aggravate rather than resolve your problem. Emergency repairs and rebuilds are always given the highest priority by E•DRIVE.

If you have any questions regarding performance or possible explanations for symptoms - we encourage early contact with E•DRIVE to help define the problem and determine the most appropriate resolution. You can also check the F.A.Q.'s page on our web site, www.edrivedesign.com, for answers to common questions.

When you call, it is most helpful if you have the actuator serial number available. This is a number with a “P” prefix and is inscribed on a metal tag directly on the front cap.

Gearbelt Installation/Tensioning

(see diagram on the next page)

Remove the belt housing cover. Loosen the (4) screws in the rear cap but DO NOT remove them. This will allow you to slide the motor mounting plate toward the actuator body. It both pulleys have flanges, it may be necessary to unbolt the motor in order to remove or install the gearbelt. Install the gearbelt. Then re-assemble with the correct tension and alignment. For detailed tensioning instructions, go to www.edrivedesign.com/service.html.

Gearbelt drives do not need to be extremely tight such as other belt drives (V-belt, Poly-V, Flat belt, etc.). If belt tension is too great, it imposes excessive and unnecessary loading on bearings. When belt is too loose (particularly on high torque applications), belt may jump teeth.

E•DRIVE Linear Actuators

Gearbelt Installation/Tensioning continued

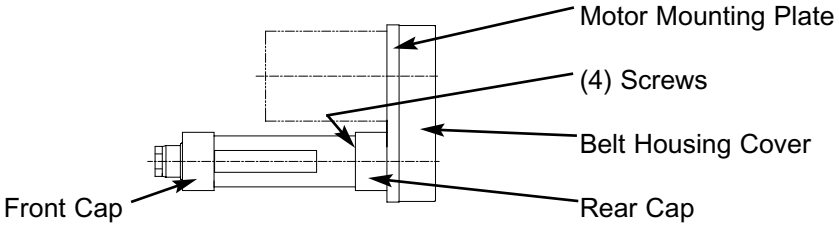

Switch Wiring

Supplied Hall Effect or Reed type switches are for “home” sensing and over-travel protection only. They should not be used as position switches.

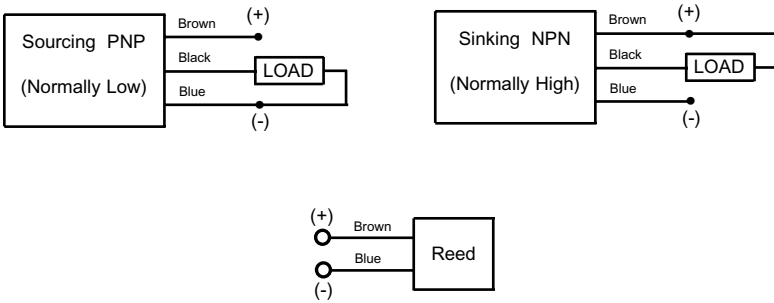

	Configuration	State	Voltage	Current	Part Number	H						
						1	2	3	4	5	6	
A	Hall Effect, Sourcing	N.O.	5-24 VDC	500 mA max.	PNP	MLE-K72			1	2	2	1
A	Hall Effect, Sourcing	N.C.	5-24 VDC	500 mA max.	PNP	MLE-Q06						
B	Hall Effect, Sinking	N.O.	5-24 VDC	500 mA max.	NPN	MLE-G06						
B	Hall Effect, Sinking	N.C.	5-24 VDC	500 mA max.	NPN	MLE-J72	1	2			1	2
C	Reed	N.O.	5-125 VAC/DC	500 mA max.	n/a	MLE-D06						
C	Reed	N.C.	5-125 VAC/DC	500 mA max.	n/a	MLE-T06						

- Cable - PVC Jacket; 24 AWG 105 strand
 - Brown (+), Blue (-), Black (load)
- Switch response: 0.01 ms
- Operating temperature: -10 to 60° C
- Shock resistance: 50 g Hall; 30 g Reed
- Vibration resistance: 30 g
- Magnetic field required: 40 gauss minimum, no upper limit

Notes

Warranty

1. E•DRIVE Design, Inc. warrants that all models of our ball screw linear actuators shall be free from defects in material and workmanship for a period of twelve (12) months beginning with initial installation or ninety days from date of shipment, whichever occurs first. Further, Models HD, SD, HDL, and MT, shall be free from defects in material and workmanship for an additional period of forty eight (48) months from the date of the expiration of the initial twelve (12) months standard warranty provided by E•DRIVE Design, Inc.

E•DRIVE's obligations under the aforesaid warranty shall be limited to repairing or replacing any part or parts of the Products, which if properly installed, used and maintained, prove defective in material or workmanship. Any freight charges and traveling expenses of E•DRIVE Design service personnel shall be the responsibility of the Buyer.

Such repair or replacement shall be E•DRIVE's sole obligation and Buyer's sole remedy hereunder and shall be conditioned upon E•DRIVE's receipt of written notice of any alleged defect within thirty (30) days after its discovery, and at E•DRIVE's option return of such defective Products or part thereof freight prepaid to Company's principal place of business. Any Product repaired or replaced pursuant to this warranty will be warranted for the remainder of the original warranty period.

2. E•DRIVE's obligations under paragraph 1. hereof shall not apply to any component or part of the Products sold hereunder which:

- (a) Is consumed by normal wear and tear, or
- (b) Which is consumed by operation above rated capacity or excessive use, or
- (c) Which has a normal life inherently shorter than the herein stated warranty period, or
- (d) Which has been damaged due to negligent or faulty use, alteration, storage, maintenance, repair or operation by Buyer, or
- (e) Which is installed or operated in disregard of the operating manual of the Products.

3. Any description or representation of the Products, whether written, in electronic media, or made orally by E•DRIVE, its agents, specifications, samples, models, bulletins, drawings, diagrams, engineering sheets or similar materials used in connection with Buyer's order are for the sole purpose of identifying the Products and shall not be construed as an express warranty.

E•DRIVE Linear Actuators

Any suggestions by E•DRIVE Design, Inc. or E•DRIVE's agents regarding use, application or suitability of the Products shall not be construed as an express warranty unless confirmed to be such in writing by E•DRIVE Design, Inc. Performance figures and specifications by E•DRIVE Design, Inc. are estimates only and are not warranties, unless expressly stated otherwise.

4. THE WARRANTY EXPRESSED HEREIN SHALL BE IN LIEU OF ANY OTHER WARRANTIES, EXPRESSED OR IMPLIED, INCLUDING, WITHOUT LIMITATION, ANY IMPLIED WARRANTY OF MERCHANTABILITY OR FITNESS FOR A PARTICULAR PURPOSE, AND IS IN LIEU OF ANY AND ALL OTHER OBLIGATIONS OR LIABILITY ON E•DRIVE .

Warranty Claims, Inspection, and Waiver of Defects

- (1) Written notice of any alleged covered defect must be presented to E•DRIVE immediately upon discovery of the defect, and E•DRIVE must be allowed to inspect the Products while they are in the alleged defective condition.
- (2) Use of the Products must be suspended until written clearance is issued by E•DRIVE for continual use, provided that E•DRIVE, upon receipt of written notice of an alleged effect, proceeds without unreasonable delay to remedy any defect coming within the warranty.
- (3) Buyer shall inspect all Products immediately upon their arrival and shall immediately give written notice to E•DRIVE of any claim that the Products do not conform to the terms of the contract. E•DRIVE shall have reasonable access to inspect any allegedly non-conforming Products.

Limitation of Liability

- (1) Except as otherwise agreed in writing, E•DRIVE's liability with respect to the Products be limited to the warranty provided above, and shall be limited to the contract price.
- (2) E•DRIVE DESIGN, INC. SHALL NOT BE SUBJECT TO ANY OTHER OBLIGATIONS OR LIABILITIES, WHETHER ARISING OUT OF BREACH OF CONTRACT, WARRANTY, TORT (INCLUDING NEGLIGENCE AND STRICT LIABILITY), OR OTHER THEORIES OF LAW, WITH RESPECT TO THE PRODUCTS SOLD OR SERVICE RENDERED BY E•DRIVE Design, Inc., OR UNDERTAKINGS, ACTS OR OMISSIONS RELATING THERETO.
- (3) UNDER NO CIRCUMSTANCES WILL E•DRIVE DESIGN, INC. BE LIABLE FOR ANY INCIDENTAL OR CONSEQUENTIAL DAMAGES, OR FOR ANY OTHER LOSS, DAMAGE OR EXPENSE OF ANY KIND, INCLUDING LOSS OF PROFITS, ARISING IN CONNECTION WITH THE CONTRACT OR WITH THE USE OR LIABILITY TO USE E•DRIVE DESIGN'S PRODUCTS FURNISHED UNDER THIS CONTRACT.
- (4) E•DRIVE'S SOLE LIABILITY AND BUYER'S SOLE REMEDY IS LIMITED TO EITHER:
 - (a) REPAIR OR REPLACEMENT OF DEFECTIVE PARTS OR PRODUCTS, OR AT E•DRIVE DESIGN' OPTION,
 - (b) RETURN OF THE PRODUCTS TO E•DRIVE DESIGN, INC.AND REFUND OF PURCHASE PRICE.

5. Without limiting the generality of the foregoing, E•DRIVE Design, Inc. specifically disclaims any liability for property or personal injury damages, penalties, special or punitive damages, damages for lost profits or revenues, loss of use of the Products or any associated equipment, cost of capital, cost of repairs to the Products subject to E•DRIVE warranty performed by persons other than E•DRIVE without E•DRIVE's prior written consent, cost of substitute products, facilities or services, down-time or slow-down costs or for any other types of economic loss, and for claims of Buyer's customers or any third party for any such damages. E•DRIVE disclaims any liability for any claim, whether in contract or in tort, which arose more than (2) years prior to the initiation or arbitration or litigation by Buyer against E•DRIVE Design, Inc.

