

PRODUCT ORDERING GUIDE

Eliminator Series MT

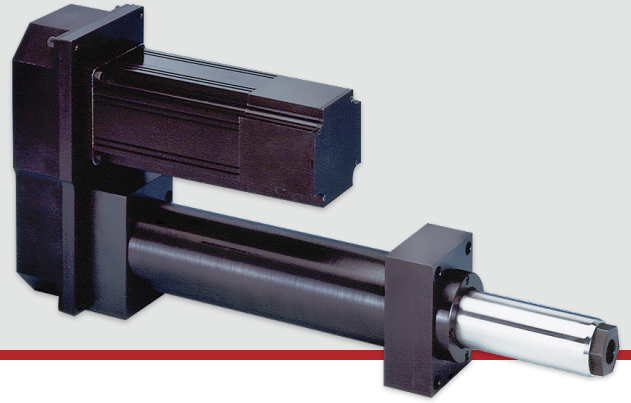

Custom products are available.

Contact sales@edriveactuators.com with your requirements.

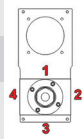
BASE NUMBER					OPTIONS					SPECIAL									
M	T																		
Base Parts No. (Capacity)					Unit Mounting Option					Motor Position					Custom Length (in)				
MT304 (4,000 lbf) MT506 (6,000 lbf) MT512 (12,000 lbf) MT515 (15,000 lbf)					MB: Bottom Mount FF: Front Flange MF: Foot Mount TF: Front Trunnion TR: Rear Trunnion					1, 2, 3, 4 0 = In-Line 					00.00				
Std. Stroke Lengths*					End Effector/Rod End					Lubrication Position					Precision/Lead Accuracy				
06: 6 in. 12: 12 in. 18: 18 in. 24: 24 in. 30: 30 in. 36: 36 in. 42: 42 in.					F: Female Thread M: Male Thread					1, 2, 3, 4 (Refer to motor diagram)					A: .0005 in/ft Preload Relieved B: .0002 in/ft Zero Backlash C: .0002 in/ft Preload Relieved				
					Configuration					Gearbelt Reduction									
					L: In-Line U: Parallel Offset					00: In-Line/Direct Coupled 10: 1:1 20: 2:1									

* MT304 is available with stroke lengths up to 30 in.
 MT506 and MT512 are available with stroke lengths up to 42 in.
 MT515 is available with stroke lengths up to 36 in.